

B-1424-8-SM-1 · BENCHES

Bench 1424-8-SM-1



STANDARD CONFIGURATION

Dimensions configured to order.

MATERIALS & CONSTRUCTION

- Laser-cut and formed steel, fully welded.
- Fabricated under one roof in Roanoke, Virginia.
- Multi-stage marine-grade powder-coat finish.

BUILT TO ORDER

Every model is a starting point. Modify size, finish, mounting, and branding to suit the site.

CUSTOMIZE

- Size** Lengths, depths, and back height built to the dimension you specify.
- Finish** Any powder-coat color, standard or custom match.
- Mounting** Surface, in-ground, or freestanding.
- Branding** Laser-cut logos, plaques, and donor recognition integrated into the piece.

WARRANTY

Frame warranted against structural defect; powder-coat finish warranted against failure under normal public-realm use. Full terms on request.

Sales Order: 11578-F	Custom Metal Bench	
Item: n/a	No. B-1424-8-5M	
Finish: Gun Metal Powder Coat	<input type="checkbox"/> approved <input type="checkbox"/> approved as noted <input type="checkbox"/> not approved revise as noted	Date 10.16.20 BY MBC Scale 3/32" = 1"
Other: n/a	PHONE: 540.342.1548	FAX: 540.342.1417
	WEB: RCLFINC.COM	



Renaissance reserves the right to make adjustments during fabrication to ensure product integrity, performance, and meet applicable UL standards.

* revised per red lines_MCO - 11/23/20
 * revised per customer redlines_MC - 02/15/21
 * added arm slat detail_MC - 02/24/21

Top View

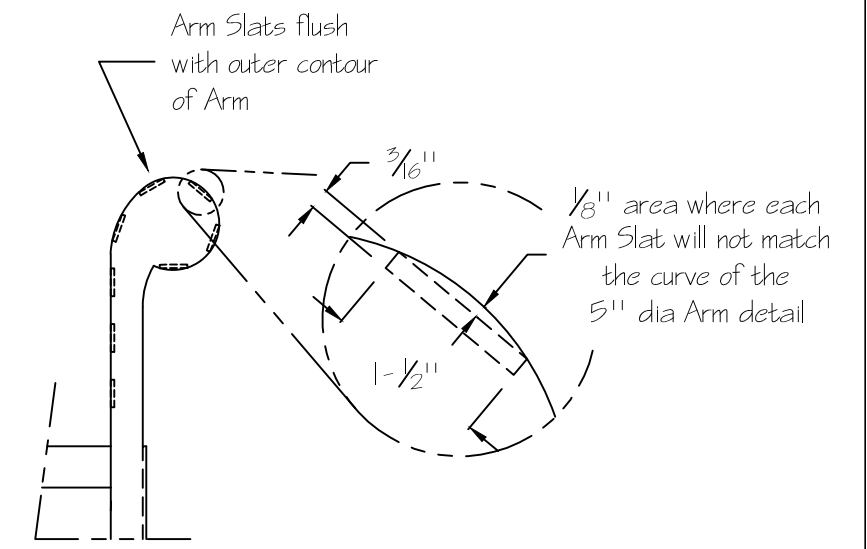
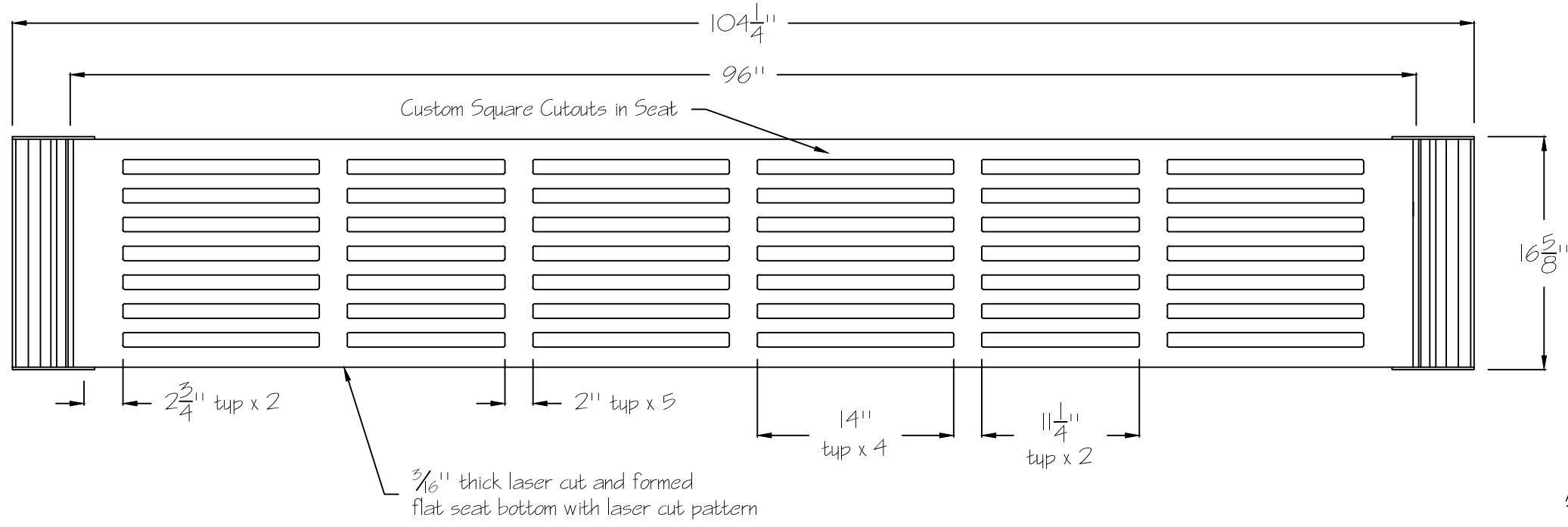

Arm Slat Detail

Front View

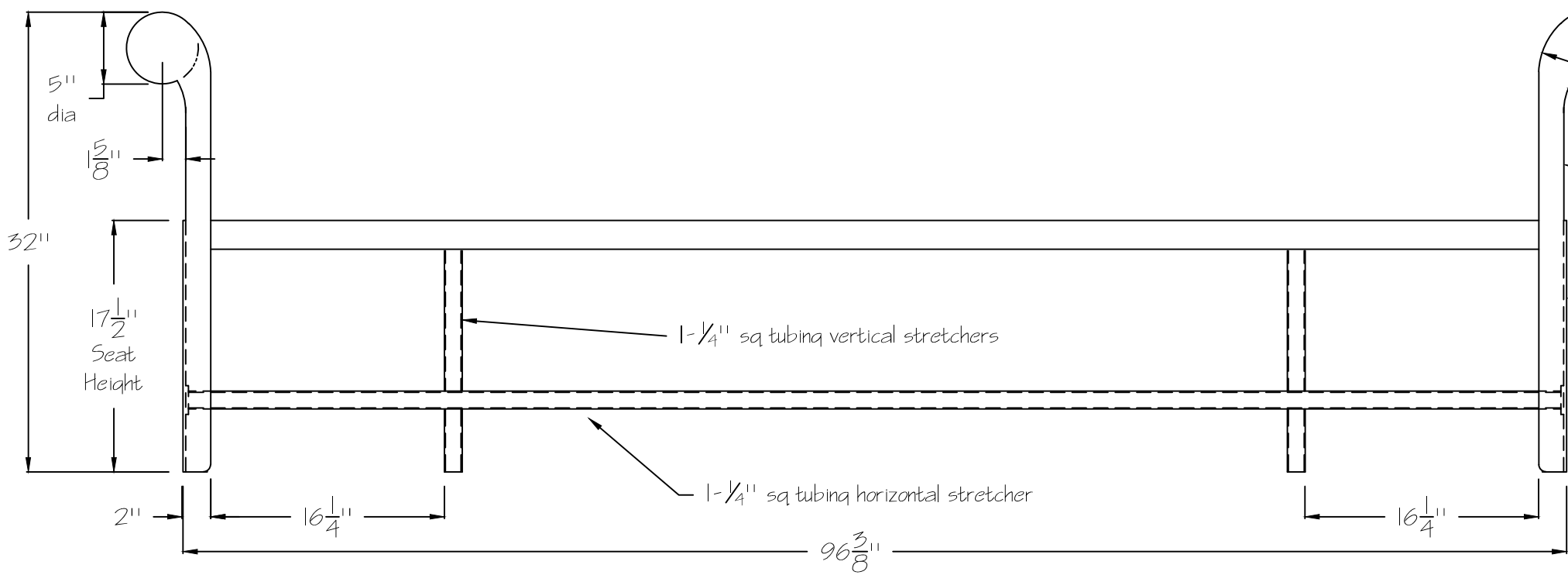

3/16" x 1-1/2" thick laser cut arm slats Side View

