



Sales Order: 8727-F

Custom Bench

Date 12.29.16

Item: n/a

No: B-1430-6-5M

Scale N.T.S

Finish: Powder Coat - To be approved

approved

approved as noted

not approved revise as noted

PHONE 540.342.1548 FAX 540.342.1417  
WEB RCLFINC.COM



1/8" thick laser cut and formed seat

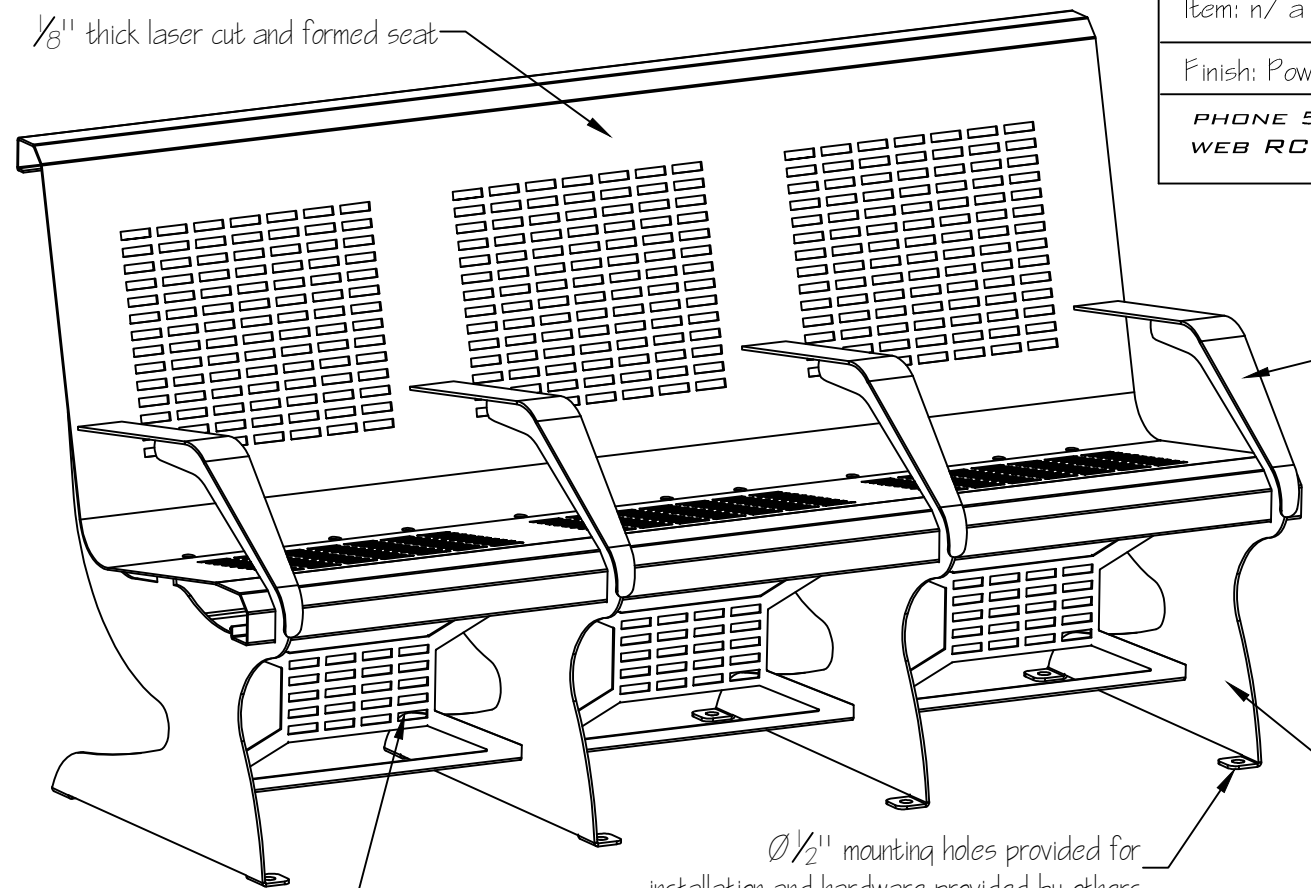

3/16" thick arms

Ø 1/2" drain holes

3/16" thick seat plates

Ø 1/2" mounting holes provided for installation and hardware provided by others

1/8" thick laser cut and formed supports

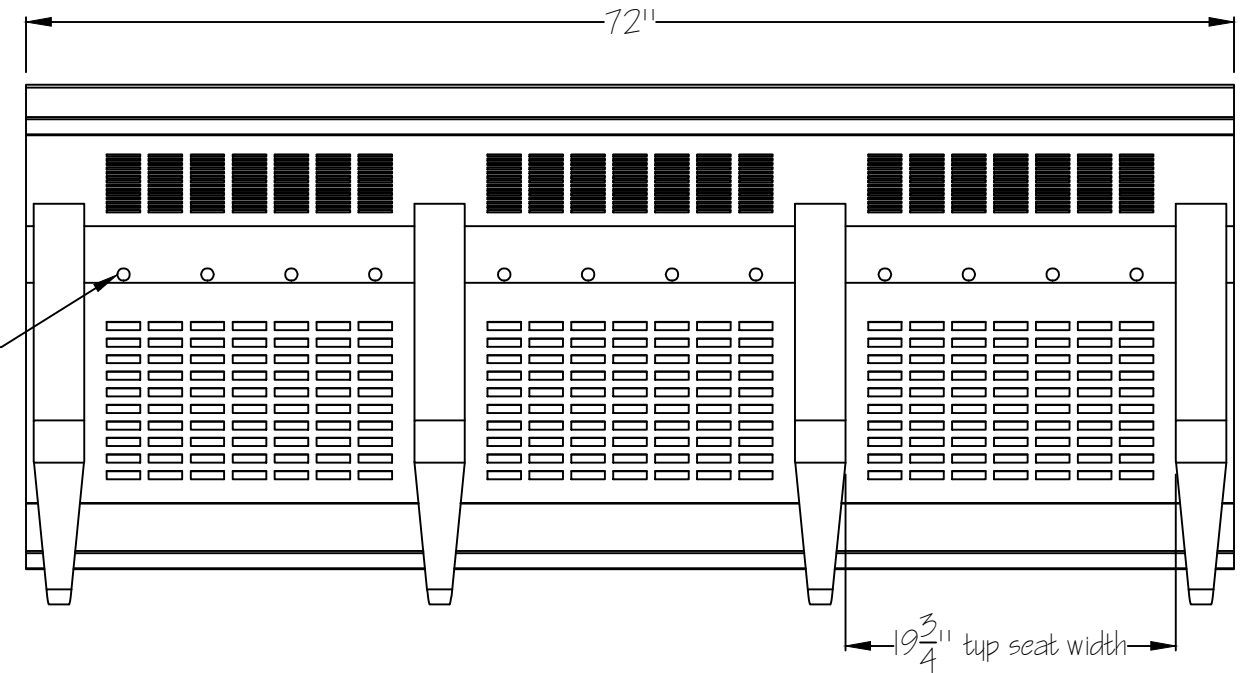

72"

19 3/4" top seat width

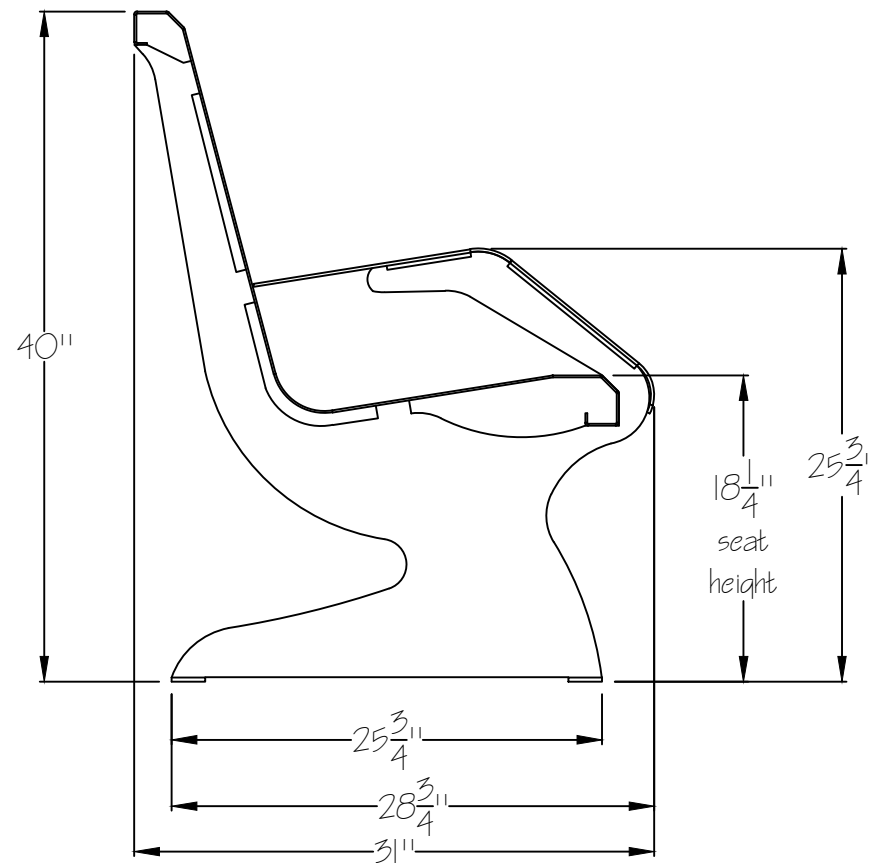

40"

18 1/4" seat height

25 3/4"

25 3/4"

28 3/4"

31"

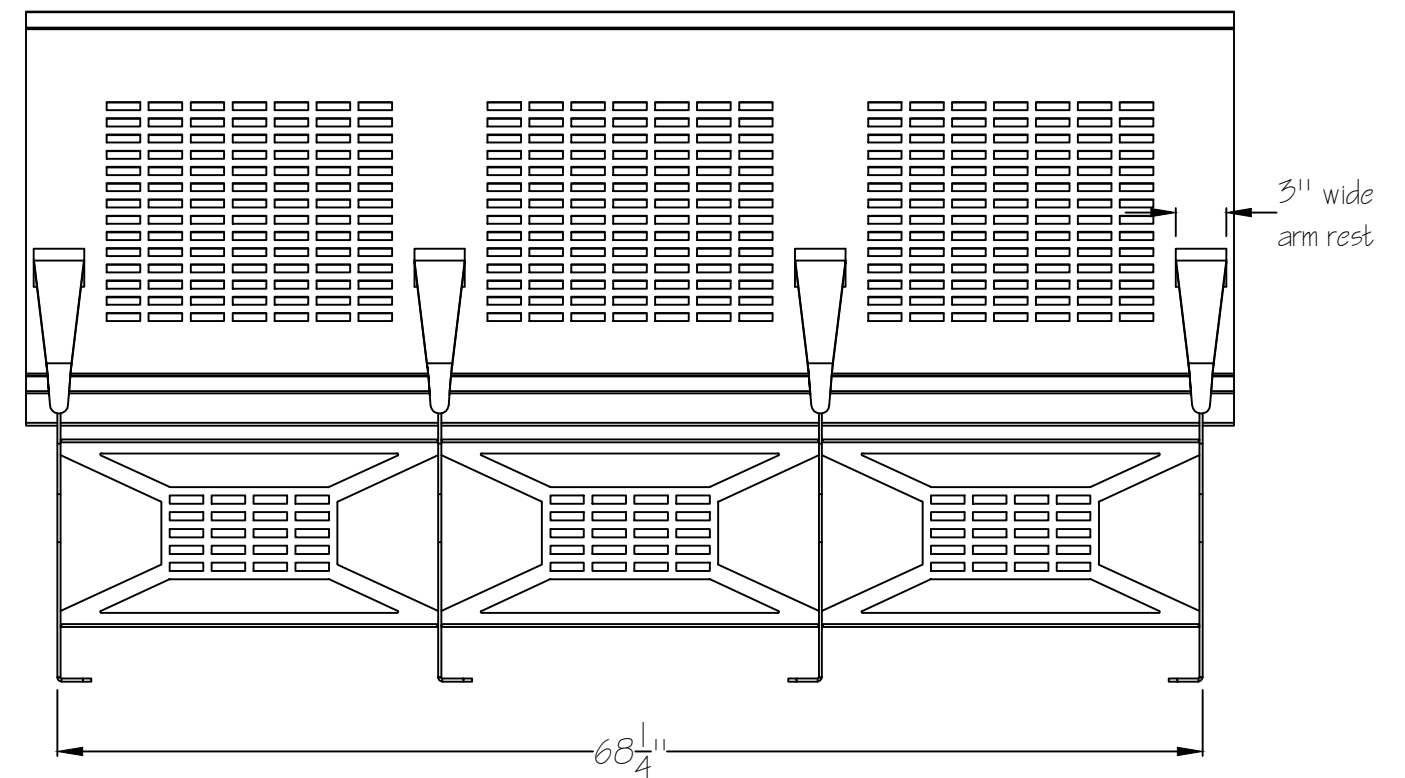

3" wide arm rest

68 1/4"