

B-1473-6-SM-FLATBAR · BENCHES

# Bench 1473-6-SM-FLATBAR



## STANDARD CONFIGURATION

Dimensions configured to order.

## MATERIALS & CONSTRUCTION

- Laser-cut and formed steel, fully welded.
- Fabricated under one roof in Roanoke, Virginia.
- Multi-stage marine-grade powder-coat finish.

## BUILT TO ORDER

Every model is a starting point. Modify size, finish, mounting, and branding to suit the site.

## CUSTOMIZE

- Size** Lengths, depths, and back height built to the dimension you specify.
- Finish** Any powder-coat color, standard or custom match.
- Mounting** Surface, in-ground, or freestanding.
- Branding** Laser-cut logos, plaques, and donor recognition integrated into the piece.

## WARRANTY

Frame warranted against structural defect; powder-coat finish warranted against failure under normal public-realm use. Full terms on request.

Sales Order: 8325-F	Rosetta Slat Bench	Date: 7/25/16	
Item: n/a	B-1473-6-SM-Flatbar	Scale: 3/32" = 1"	
Finish: Powder Coat, Color TBD	<input type="checkbox"/> approved <input type="checkbox"/> approved as noted <input type="checkbox"/> not approved revise as noted		
PHONE 540.342.1548 FAX 540.342.1417 WEB RCLFING.COM	MBC		

ISO View

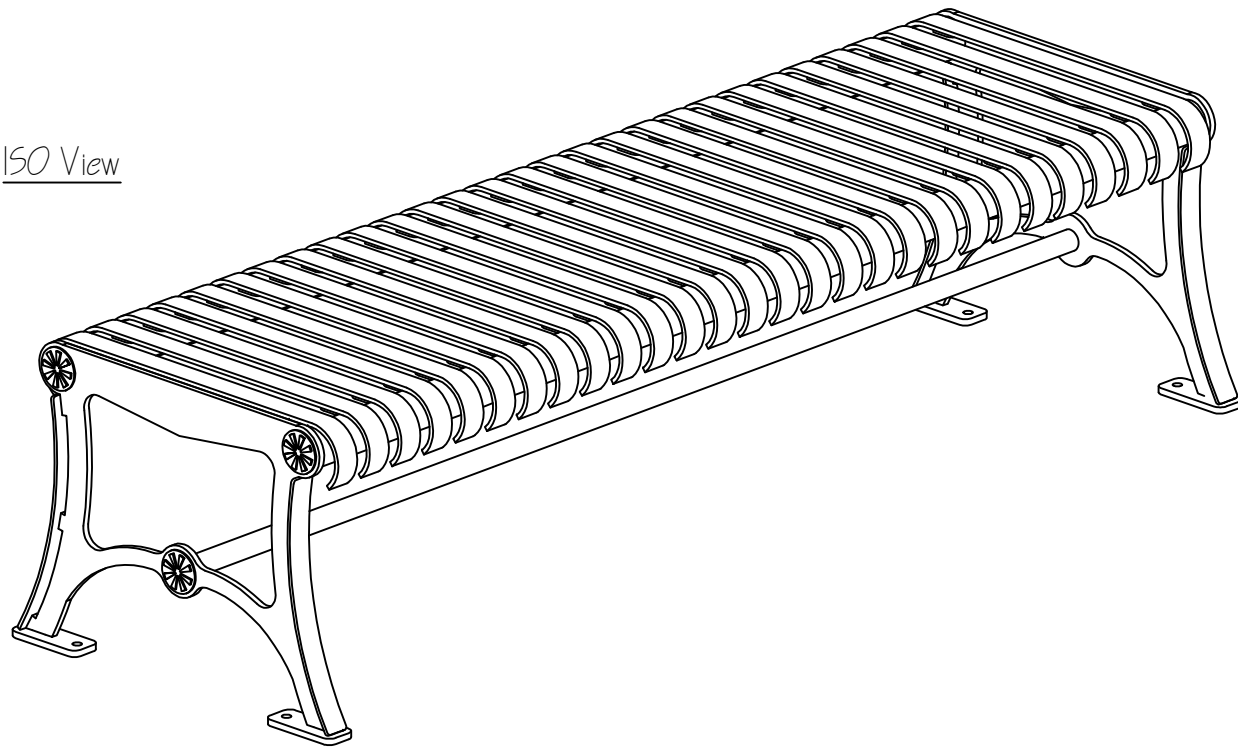

Side Elevation

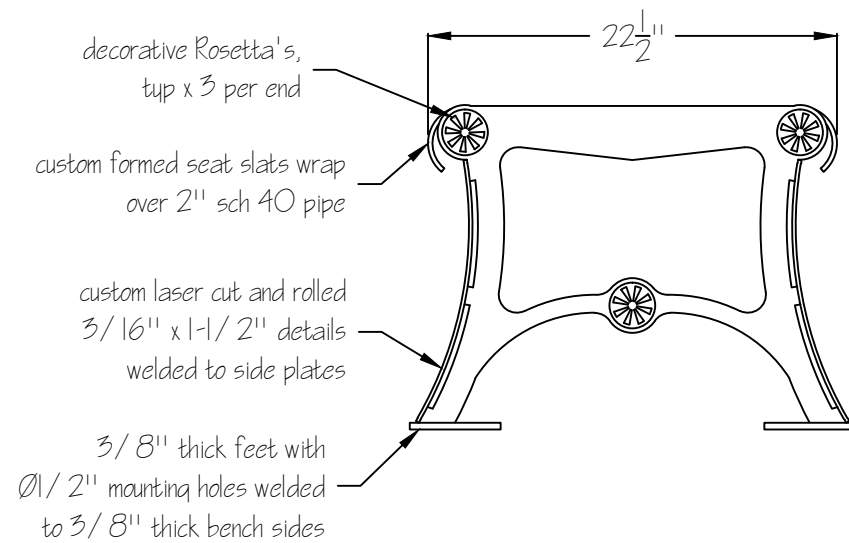

Top Elevation

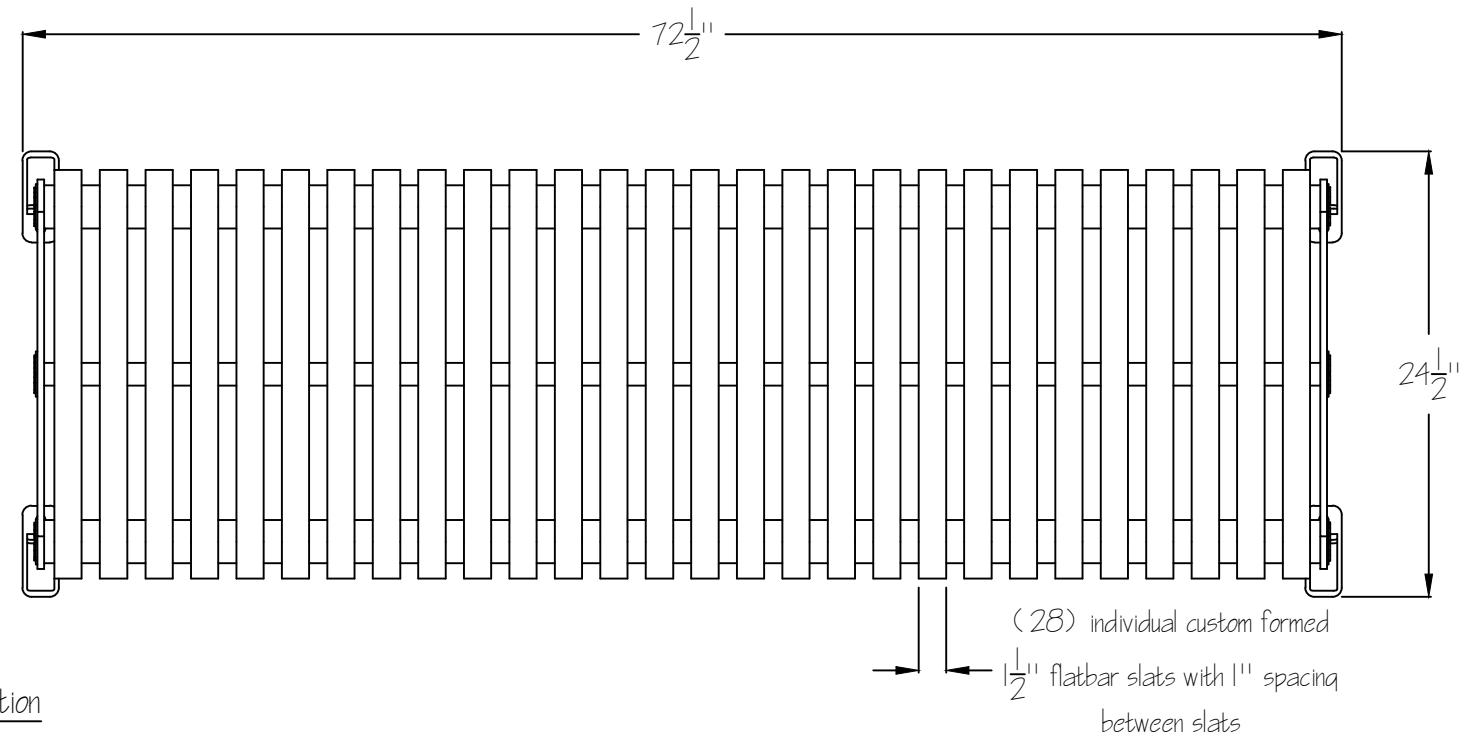

Front Elevation

