

B-1482 · BENCHES

# Razor Bench



### STANDARD CONFIGURATION

Dimensions configured to order.

### MATERIALS & CONSTRUCTION

- Laser-cut and formed steel, fully welded.
- Fabricated under one roof in Roanoke, Virginia.
- Multi-stage marine-grade powder-coat finish.

### POWDER-COAT FINISHES

- |                 |                      |                    |                    |                   |
|-----------------|----------------------|--------------------|--------------------|-------------------|
| ■ Black Peel    | ■ Black Texture      | ■ Cappuccino       | ■ Cargo Black      | ■ Chocolate Brown |
| ■ Claret-Violet | ■ Classic Grey       | ■ Cobalt Blue      | ■ Light Ivory      | ■ Fence Red       |
| ■ Fir Green     | ■ Green-Blue         | ■ Gun Metal        | ■ Glossy White     | ■ Java            |
| ■ Lemon Yellow  | ■ Light Blue         | ■ Luna             | ■ Mineral Bronze   | ■ Nut Brown       |
| ■ Olive Patina  | ■ Oxblood            | ■ Pastel Turquoise | ■ Poly Silver Vein | ■ Red Letter      |
| ■ Rust          | ■ Silver Hammerstone | ■ Safety Yellow    | ■ Star Dust        | ■ Sulfur Yellow   |
| ■ Traffic Gray  | ■ Verdi              | ■ Water Blue       | ■ White Peel       |                   |

34 standard colors · custom RAL match available

### BUILT TO ORDER

Every model is a starting point. Modify size, finish, mounting, and branding to suit the site.

### CUSTOMIZE

- Size** Lengths, depths, and back height built to the dimension you specify.
- Finish** Any powder-coat color - 34 standard options, plus custom match.
- Mounting** Surface mount, Freestanding / portable.
- Branding** Laser-cut logos, plaques, and donor recognition integrated into the piece.

### ANCHORING & ORDER CODES

- Surface mount **B-1482-SM**
- Freestanding / portable **B-1482-FS**

### WARRANTY

Frame warranted against structural defect; powder-coat finish warranted against failure under normal public-realm use. Full terms on request.

sales order 5274		Custom Surface Mounted Bench	Date 09-10-12
item 0000		N <sup>o</sup> : RF-B-0019-72	scale 3/32"=1"
finish	TBD	<input type="checkbox"/> approved <input type="checkbox"/> approved as noted <input type="checkbox"/> not approved revise as noted	
PHONE 540.342.1548 FAX 540.342.1417 WEB RCLFING.COM			



Top View

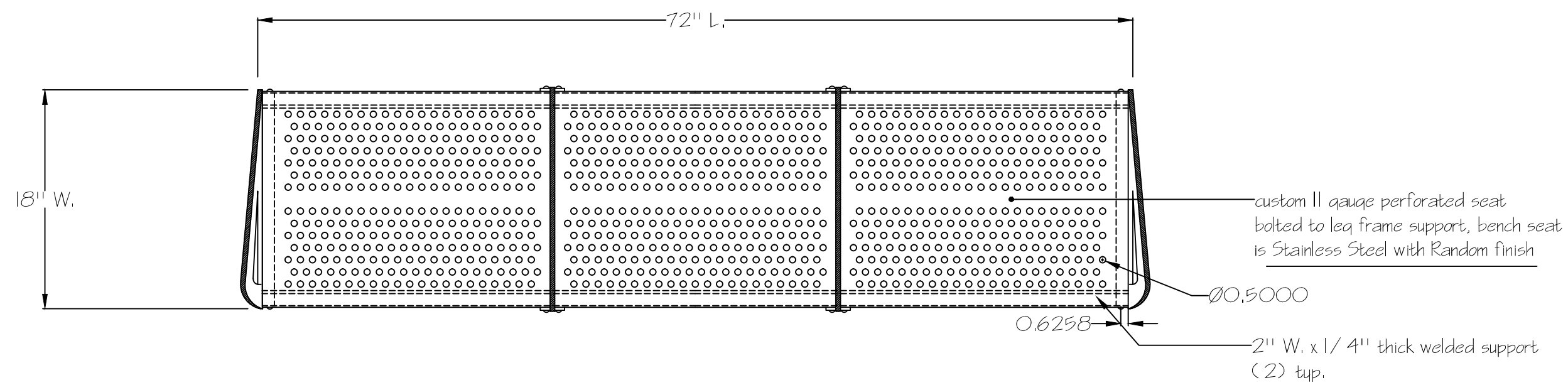

- \* custom punched seat
- \* custom laser cut details
- \* bench is bolted to floor
- \* revised 10-03-12

Front View

side and frame will be mild steel with aluminum texture finish or acceptable match

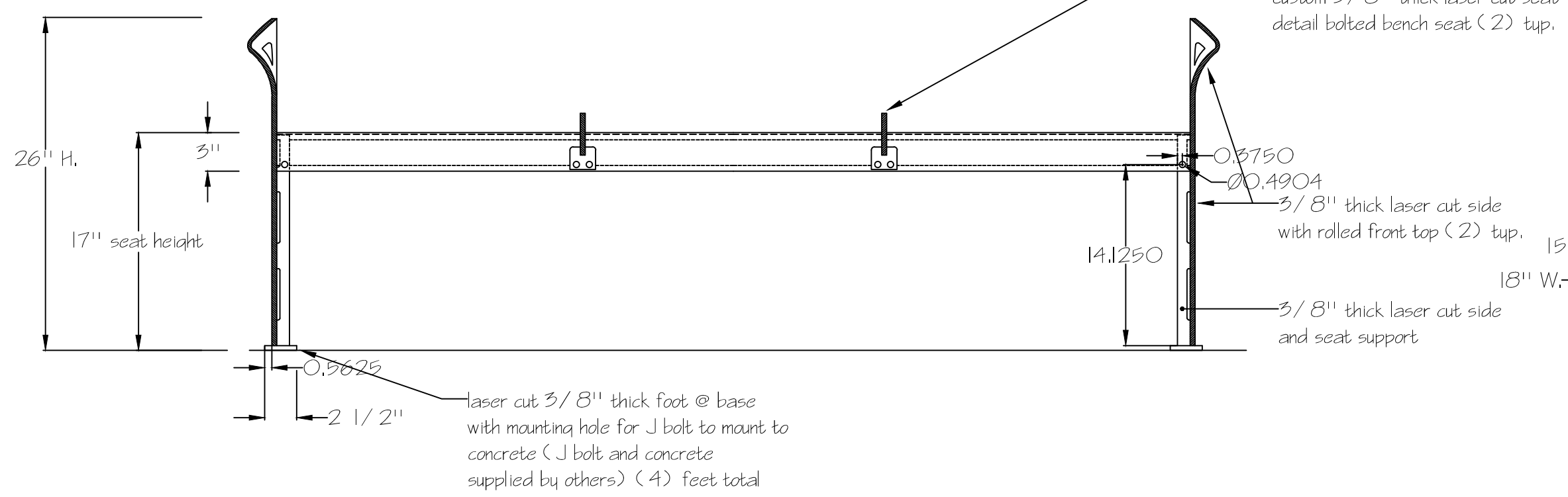

Side View

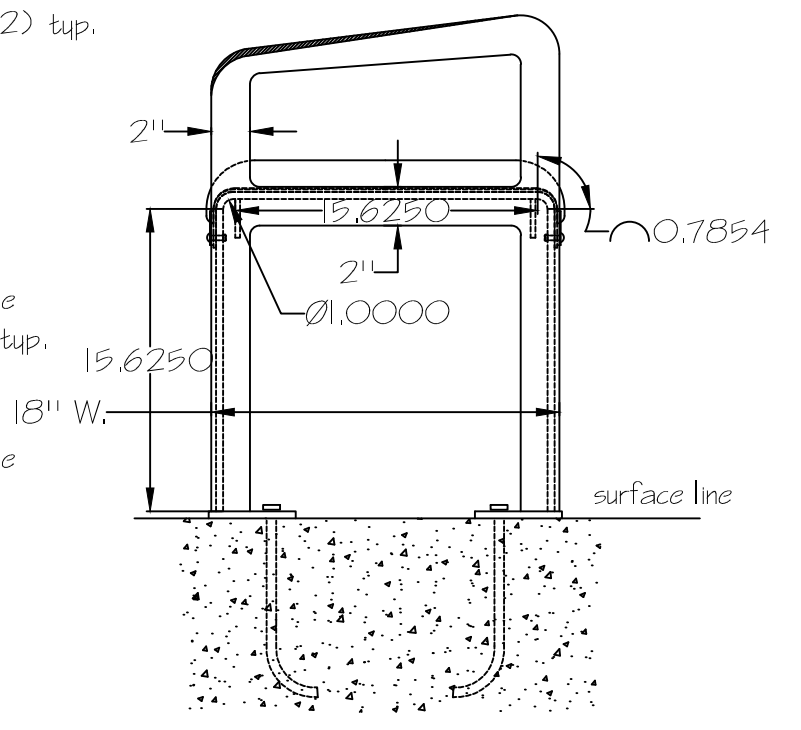

laser cut 3/8" thick foot @ base with mounting hole for J bolt to mount to concrete (J bolt and concrete supplied by others) (4) feet total