

CST-1811-3 · CAROUSEL TABLES

CST-1811-ADA 3 & U-1100-1.50 Three Bench Carousel Table with Umbrella



BUILT TO ORDER
 Every model is a starting point. Modify size, finish, mounting, and branding to suit the site.

CUSTOMIZE

- Size** Lengths, depths, and back height built to the dimension you specify.
- Finish** Any powder-coat color - 35 standard options, plus custom match.
- Mounting** Surface, in-ground, or freestanding.
- Branding** Laser-cut logos, plaques, and donor recognition integrated into the piece.

WARRANTY

Frame warranted against structural defect; powder-coat finish warranted against failure under normal public realm use. Full terms on request.

STANDARD CONFIGURATION

Dimensions CST-1811-ADA | Dimensions: | 76.52" W x 29.31" H

MATERIALS & CONSTRUCTION

- Laser-cut and formed steel, fully welded.
- Fabricated under one roof in Roanoke, Virginia.
- Multi-stage marine-grade powder-coat finish.
- ADA-compliant configuration available.

POWDER-COAT FINISHES

35 standard colors · custom RAL match available

Black Peel	Black Texture	Cappuccino	Cargo Black	Chocolate Brown
Claret-Violet	Classic Grey	Cobalt Blue	Light Ivory	Fence Red
Fir Green	Green-Blue	Gun Metal	Glossy White	Java
Lemon Yellow	Light Blue	Luna	Mineral Bronze	Nut Brown
Olive Patina	Oxblood	Pastel Turquoise	Poly Silver Vein	Red Letter
Rust	Silver Hammerstone	Safety Yellow	Star Dust	Sulfur Yellow
Traffic Gray	Verdi	Water Blue	White Peel	Copper Metallic

sales order 0000
 item 0000
 finish 13D
 PHONE 540.342.1548 FAX 540.342.1417
 WEB RCLFINC.COM

Custom Round Table
 N^o. CST-1811-ADA
 Date 09-07-11
 scale 3/32"=1"

- approved
- approved as noted
- not approved revise as noted



* drawing not for factory use

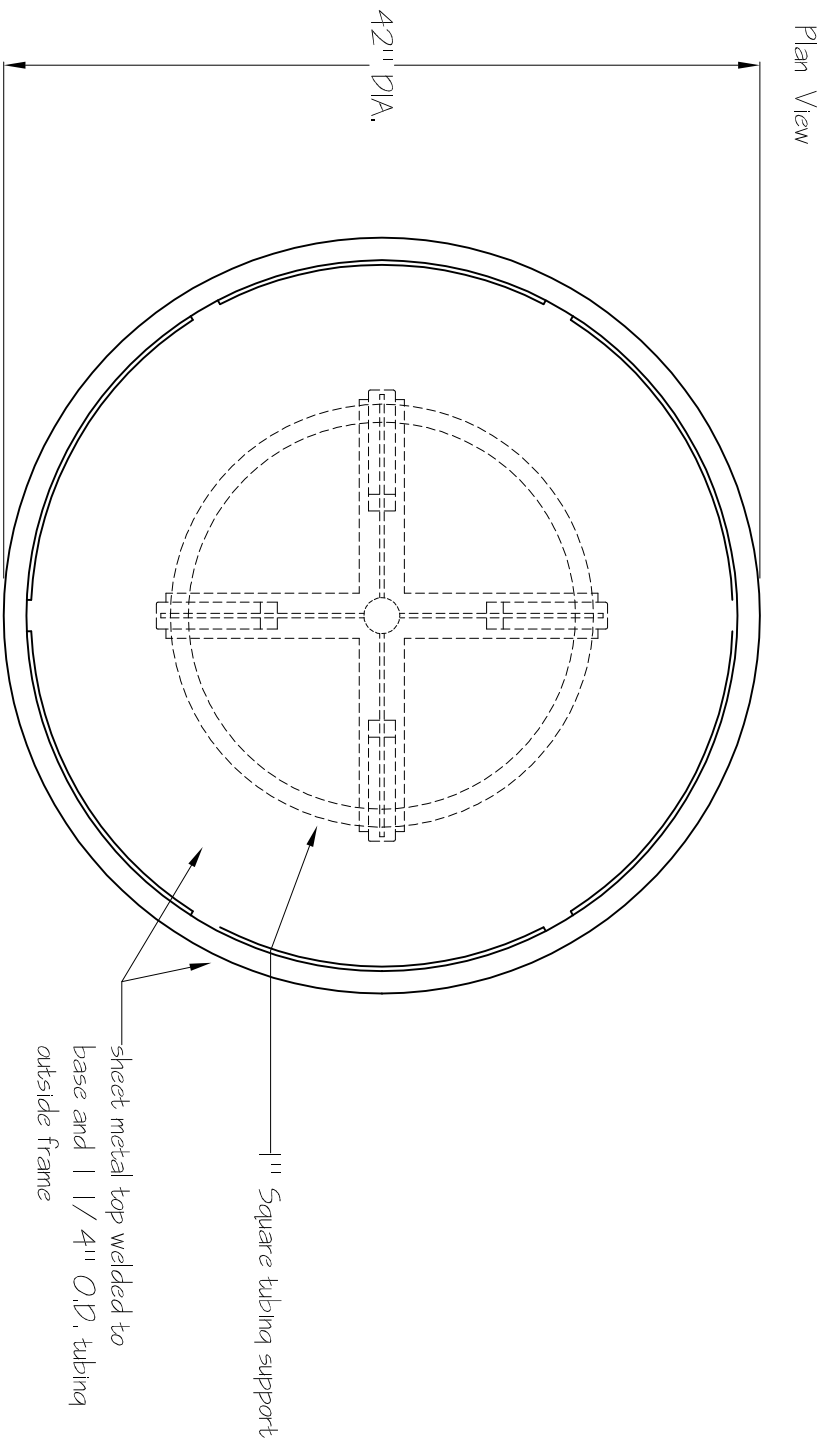

Table shown with curved matching benches not to scale

