

T-1657-5-SM · TABLES

Solar Table



BUILT TO ORDER
 Every model is a starting point. Modify size, finish, mounting, and branding to suit the site.

CUSTOMIZE

- Size** Lengths, depths, and back height built to the dimension you specify.
- Finish** Any powder-coat color - 34 standard options, plus custom match.
- Mounting** Surface, in-ground, or freestanding.
- Branding** Laser-cut logos, plaques, and donor recognition integrated into the piece.

WARRANTY

Frame warranted against structural defect; powder-coat finish warranted against failure under normal public realm use. Full terms on request.

STANDARD CONFIGURATION

Dimensions Dimensions: 96" L x 62" | W x 86-3/4" H | (Table Top, Battery Housing and Seats) | (Umbrella Frame and Panels)

MATERIALS & CONSTRUCTION

- Laser-cut and formed steel, fully welded.
- Fabricated under one roof in Roanoke, Virginia.
- Multi-stage marine-grade powder-coat finish.
- ADA-compliant configuration available.

POWDER-COAT FINISHES

34 standard colors · custom RAL match available

Black Peel	Black Texture	Cappuccino	Cargo Black	Chocolate Brown
Claret-Violet	Classic Grey	Cobalt Blue	Light Ivory	Fence Red
Fir Green	Green-Blue	Gun Metal	Glossy White	Java
Lemon Yellow	Light Blue	Luna	Mineral Bronze	Nut Brown
Olive Patina	Oxblood	Pastel Turquoise	Poly Silver Vein	Red Letter
Rust	Silver Hammerstone	Safety Yellow	Star Dust	Sulfur Yellow
Traffic Gray	Verdi	Water Blue	White Peel	

Sales Order: 10757-F

Custom Solar Charging Station

date 02/06/18

Item: n/a

No. T-1657-5-SM-ADA-VT

scale NTS

Finish: Canopy RAL3004, Mineral Bronze PC

- approved
- approved as noted
- not approved revise as noted

PHONE 540.342.1548
 FAX 540.342.1417
 WEB RCLFING.COM

Renaissance reserves the right to make adjustments during fabrication to insure product integrity, performance, and meet applicable UL standards.

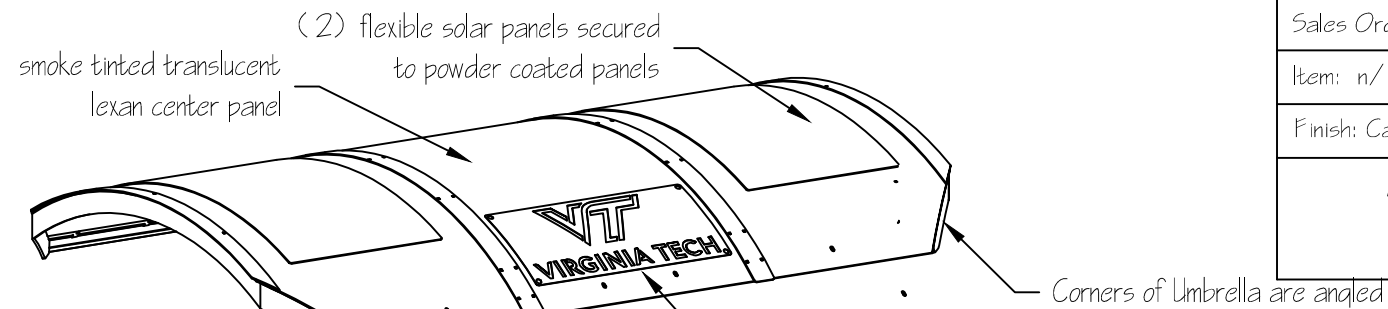

ISO VIEW

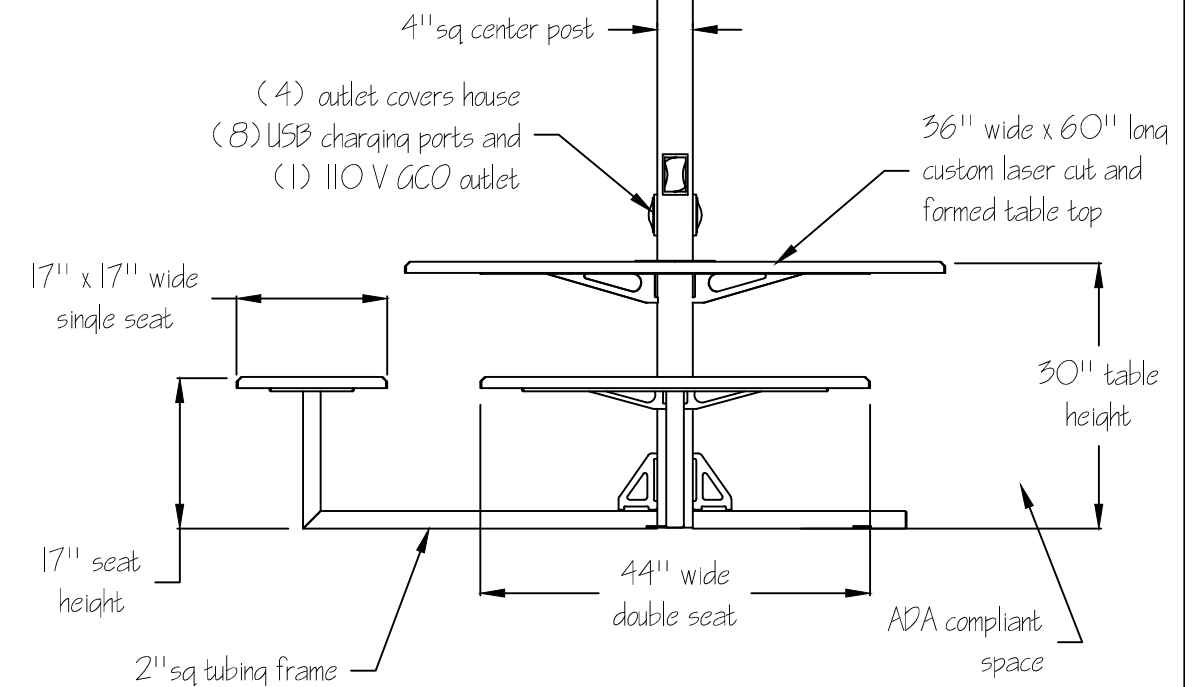
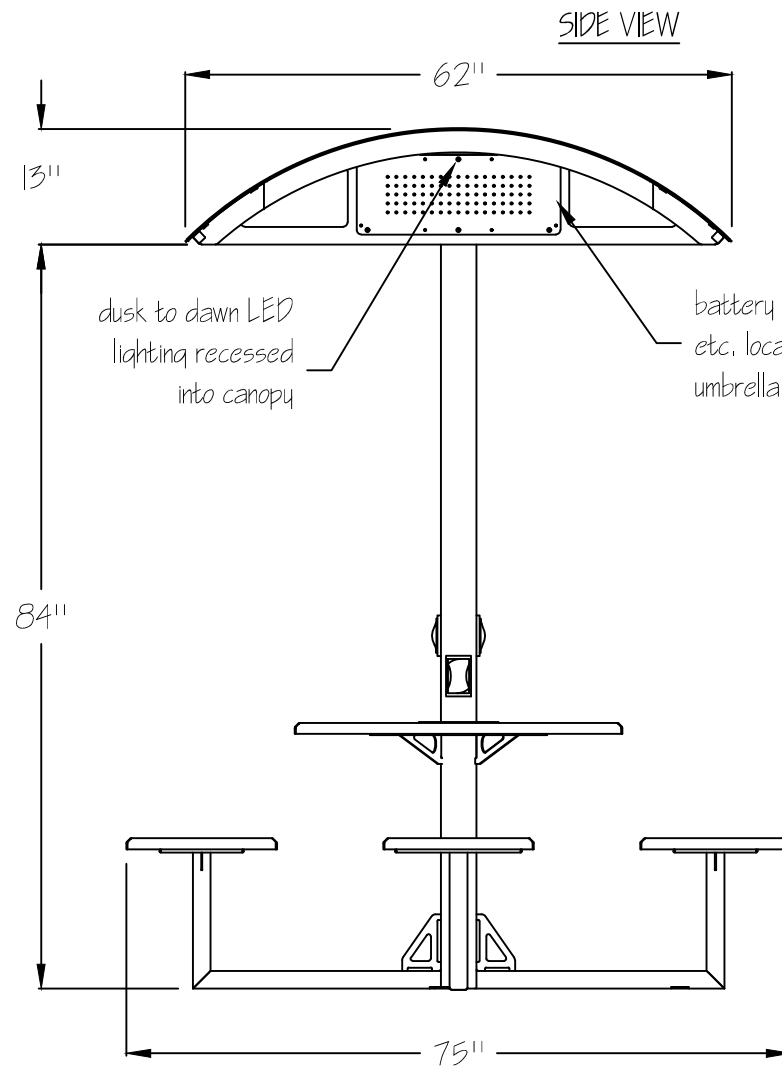
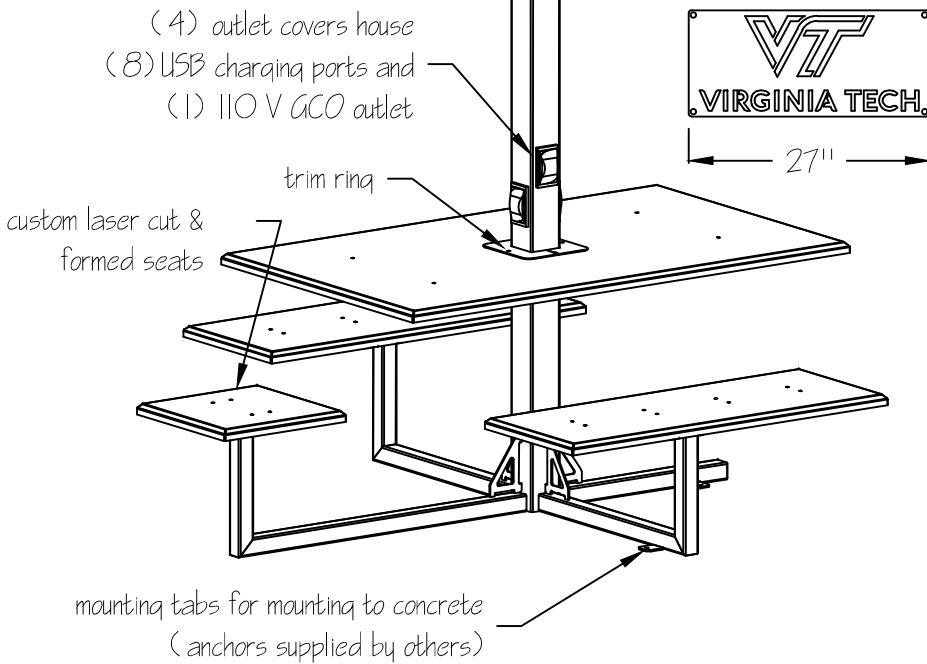

TOP VIEW

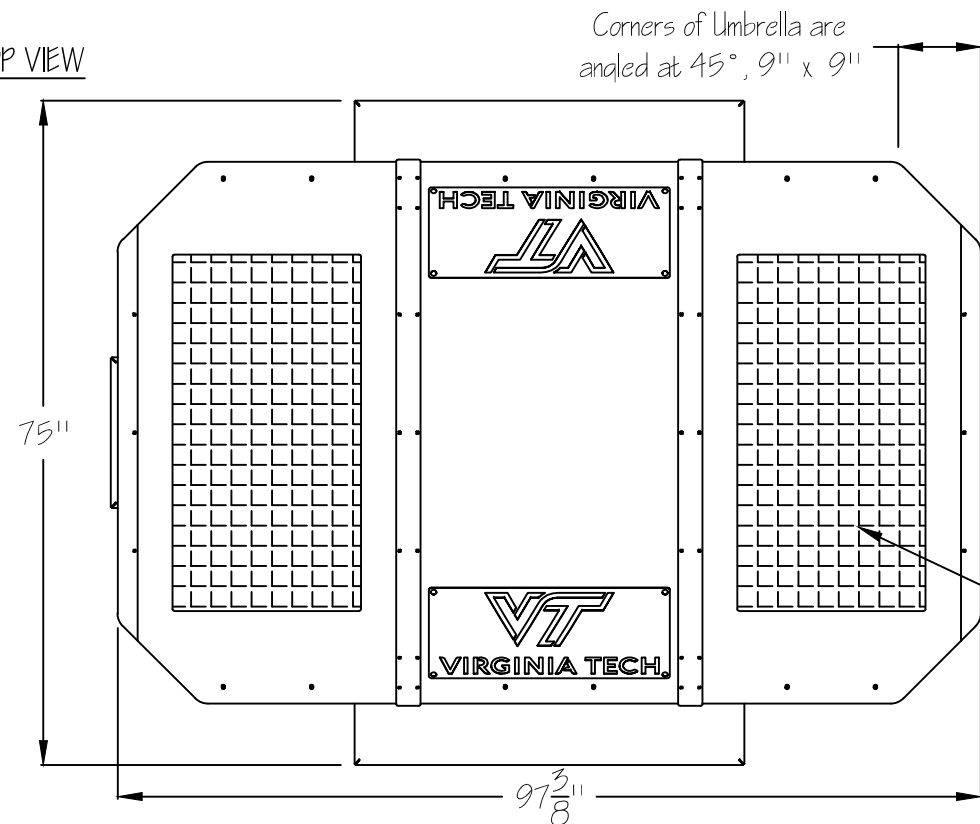

(2) flexible solar panels secured to powder coated panels

- * revised updated VT logo as of date, relocated battery placement, increased umbrella clearance height, added 110 V outlet, changed seat pattern_MC - 11.21.17
- * added angled corners to umbrella_MC - 1.4.18
- * added additional overall dims_MC - 9.8.20